

# STV-638N

FIXED TV WALL MOUNT

SOPORTE TV FIJO

SUPPORT TV FIXE

SUPORTE TV FIXO

FESTE TV-WANDHALTERUNG

STAFFA FISSA PER TV



INSTRUCTION MANUAL/MANUAL DE USUARIO  
MODE D'EMPLOI/MANUAL DE INSTRUÇÕES  
BEDIENUNGSANLEITUNG/MANUALE D'ISTRUZIONI

**FONESTAR**

# IMPORTANT/IMPORTANTE/IMPORTANT/IMPORTANTE/WICHTIG/IMPORTANTE

## EN

- 1.- Follow the installation recommendations in the instruction manual.
- 2.- The installation surface must be completely flat. Make sure the holes in the wall coincide with the holes on the plate. Screw the mount to the wall, in vertical position only.
- 3.- The mount must be properly and firmly attached to the wall or installation surface to make sure that the support holds the maximum weight. **FONESTAR** does not hold itself responsible for damage or breakages due to the mount falling away from the wall because it was incorrectly attached, the wall was in bad conditions or it was handled incorrectly.

## ES

- 1.- Siga las recomendaciones de instalación del manual de instrucciones.
- 2.- La superficie de instalación debe estar totalmente plana. Asegúrese de que los orificios de la pared están centrados con los orificios de la placa. Atornille el soporte a la pared, en posición vertical exclusivamente.
- 3.- La sujeción firme del soporte en la pared es esencial para asegurar que el soporte aguante el peso máximo. **FONESTAR** no se hace en ningún caso responsable de las averías o roturas que pudieran derivarse del desprendimiento del soporte de la pared por fallos de la misma, del sistema de sujeción o por incorrecta manipulación.

## FR

- 1.- Suivez les recommandations d'installation du mode d'emploi.
- 2.- La superficie d'installation doit être totalement plate. Assurez-vous que les orifices du mur soient bien centrés avec ceux de la plaque murale. Vissez le support au mur, uniquement en position verticale.
- 3.- La bonne fixation du support au mur, ou à la superficie d'installation, est essentielle pour garantir que le support résiste bien au poids maximum. **FONESTAR** ne se responsabilise pas des pannes ou cassures du détachement du support du mur qui pourraient être engendrés par un défaut de celui-ci, du système de fixation ou par une mauvaise manipulation.

## PT

- 1.- Siga as recomendações de instalação do manual de instruções.
- 2.- A superfície de instalação deve ser totalmente plana. Certifique-se de que os orifícios na parede estão centrados com os orifícios da placa. Aparafuse o suporte à parede, unicamente na posição vertical.
- 3.- A firme fixação do suporte na parede é essencial para assegurar que o suporte aguanta o peso máximo. **A FONESTAR** não admite qualquer responsabilidade no caso de avarias ou quebras derivadas do desprendimento do suporte da parede por falhas na mesma, do sistema de fixação ou má utilização.

## DE

- 1.- Folgen Sie den Empfehlungen für die Installierung in der Bedienungsanleitung.
- 2.- Die Oberfläche muss für die Installierung vollkommen eben sein. Versichern Sie sich, dass die Befestigungsbohrungen mit den Löchern auf der Platte übereinstimmen. Befestigen Sie die Halterung nur im senkrechten Sinn.
- 3.- Nur eine feste Halterung an der Wand stellt sicher, dass sie das Maximalgewicht tragen kann. **FONESTAR** übernimmt keine Verantwortung für Schäden oder Brüche, die durch das Herabfallen der Halterung zurückzuführen sind und auf den Zustand der Wand beruhen, sowie auch nicht für das Befestigungssystem oder bei unsachgemäßer Handhabung.

## IT

- 1.- Seguire le raccomandazione di installazione del manuale d'istruzioni.
- 2.- La superficie di installazione deve essere completamente piana. Assicurarsi che i fori nel muro siano centrati e corrispondano con quelli fatti nella piastra. Avvitare la staffa alla parete solo in posizione verticale.
- 3.- È fondamentale il fissaggio sicuro della staffa alla parete per assicurare la capacità di resistenza al peso massimo. **FONESTAR** non si ritiene responsabile, in nessun caso, dei danni o guasti che possano insorgere a causa del distacco della staffa dal muro a seguito un'installazione scorretta, errori nel modo di fissaggio o manipolazione sbagliata.

**ACCESSORIES INCLUDED/ACCESORIOS INCLUIDOS/ACCESSOIRES INCLUS/  
ACESSÓRIOS INCLUIDOS/ENTHALTENDE ZUBEHÖRTEILE/ACCESSORI INCLUSI**

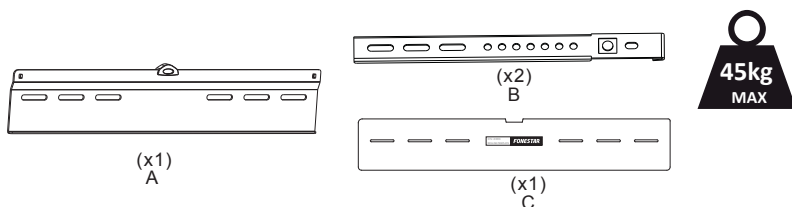

M5x14 (x4)  
M-A



M6x14 (x4)  
M-B



M8x20 (x4)  
M-C



M6x30 (x4)  
M-D

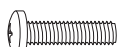

M8x30 (x4)  
M-E



(x4)  
M-F



Ø8x5 (x8)  
M-G



Ø8x15 (x4)  
M-H

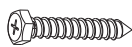

ST6.3x55 (x4)  
W-A



10x45 (x4)  
W-B



Ø6 (x4)  
W-C

**ASSEMBLY INSTRUCTIONS/INSTRUCCIONES DE MONTAJE/INSTRUCTIONS POUR  
LE MONTAGE/INSTRUÇÕES DE MONTAGEM/MONTAGEANLEITUNG/ISTRUZIONI  
PER IL MONTAGGIO**

**1**

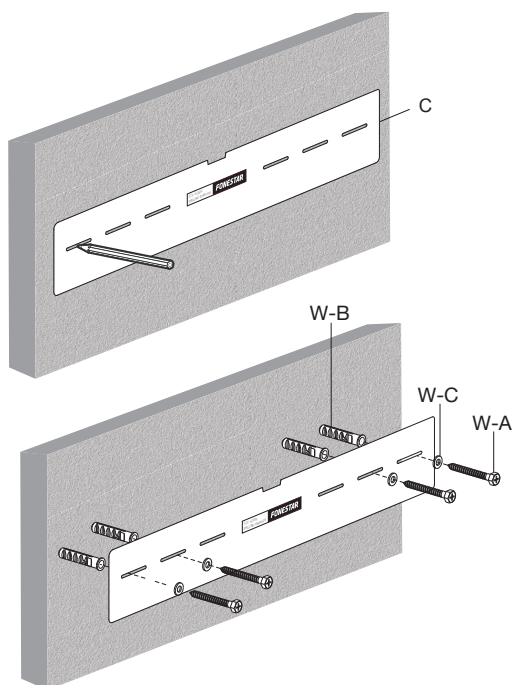

2

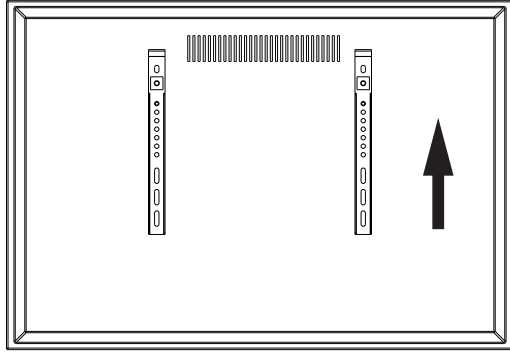

2a

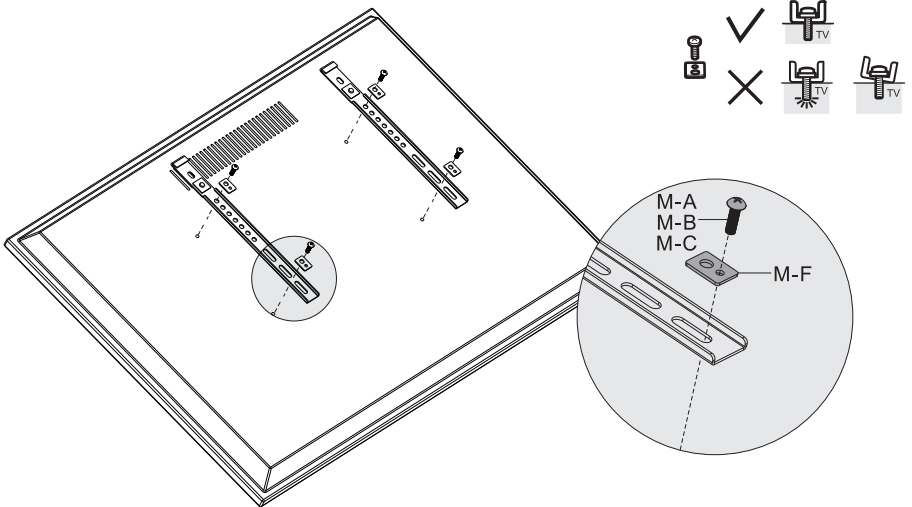



2b

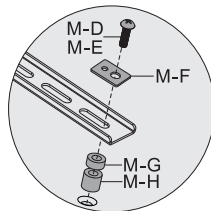
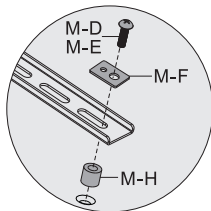
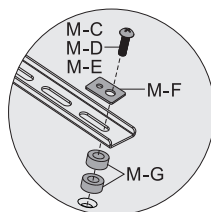
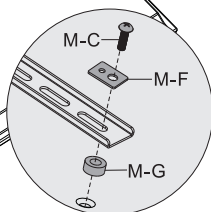
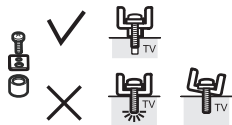
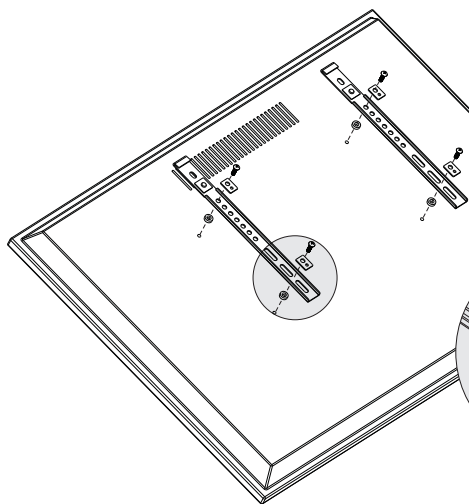

3

